Ionut-Tudor MARIES

Date of birth: 20.01.1989

Address: Cluj-Napoca, Romania

Telephone: +40 742 738 832

E-mail: ionut.maries@gmail.com

LinkedIn: <http://www.linkedin.com/in/imaries>



Professional Experience:

10/2017-10/2020

Research Assistant within project PCCDI 22/2018

Technical University of Cluj-Napoca, *Engineering and Technology*

- Contributions to research on the development of robotic systems used in the sorting of solid waste.

10/2017-10/2020

PhD Scholar

Technical University of Cluj-Napoca, *Engineering and Technology*

- Conducting R&D activities in miniaturized intelligent storage and release systems for mechanical energy.
- Working on developing ergonomic and intuitive bio mechanical performance enhancing solutions for individuals and amateur athletes.

05/2016-07/2017

Product Manager / Business Analyst

Starport, *UX/UI Design and Digital Product Development*

- Groomed, conceptualized and developed digital products for several industries including medical, entertainment, sport, construction, services (translation, accounting).
- Collected and managed business, functional as well as non-functional requirements.
- Consulted with clients on best practices, business priorities and development stages.
- Worked closely with design and development to gradually implement new features and functionalities for client's digital products.
- Maintained relationship with clients by communicating on a daily basis.
- Maintained relationship with IT association members.
- Represented company in national and international fairs and conventions.
- Conceptualized, developed and managed projects that have an estimated revenue of over £1 million / year.

09/2014-04/2016

Marketing and Business Development Specialist

Evozon Game Studio, *Mobile Gaming Division*

- Managed sales and distribution of 3D assets on 7 marketplaces.
- Analyzed the 3D assets industry and recommended ways to increase sales.
- Analyzed mobile gaming competition on iOS AppStore and Google Play and recommended ways to overpass the competition.
- Performed focus groups and product testing before product launches.
- Managed STEAM Greenlight campaign for PC game.

- Represented company interests in international economic missions, international fairs and technology conventions.
- Developed and maintained relationships with game publishers and partners.

11/2013-09/2014

Marketing Specialist

AROBSTransilvania Software, *Software Outsourcing Division*

- Identified and informed clients about the company's activity and products.
- Analyzed marketing promotions and recommended most advantageous means of promotion.
- Participated in national and international fairs.
- Organized marketing related events to promote company or company products.
- Offered marketing support to sales and development departments.

08/2013-present

Brand Ambassador / Insider

Lenovo, *Computer Hardware*

- Write articles and reviews related to Lenovo products.
- Participate in monthly calls with Lenovo Executives referring to new product releases.
- Always promote the Lenovo brand with all means necessary.

International Education – business, design and technical:

10/2017 – 10/2020

PhD Scholar in Mechanical Engineering and Mechatronics

Technical University of Cluj-Napoca, Faculty of Machine Building, Romania

04/2017 – 08/2017

Business Analyst Specialization Course

The Informal School of IT, Romania

10/2014 – 09/2016

Master of Science (MSc) in Industrial Design and Engineering

Technical University Cluj-Napoca, Faculty of Machine Building, Romania

08/2008 – 06/2011

Bachelor of Arts (BA) in International Business Communication: Marketing and Management Communication

University of Aarhus, Aarhus School of Business and Social Sciences, Denmark

10/2010 – 01/2011

Erasmus Exchange Program – Economics, Marketing and Management

University of Ljubljana, Faculty of Economics, Slovenia

09/2004 – 06/2008

Baccalaureate Degree and Certificate in Computer Programming

„Gheorghe Sincai” National College, Romania

IT, Business Analysis and Design Skills:

- **Programming and Database Systems:** I understand the logic behind any software application and have programming skills acquired during high school (I have graduated mathematics-computer science, intensive computer science) and proven by the Program Attestation obtained as well as multiple awards in the national programming contests.
- **Business Process Modelling:** UML knowledge. Used iGrafix, Draw.io and other tools for process modelling.
- **UX/UI Modelling:** Used Balsamiq and PowerPoint for basic wireframing and InVision for prototyping.

- **Microsoft Office Suite:** I am proficient in the Office suite and also possess the European Computer Driving License “ECDL Full” (Word, Excel, PowerPoint). Advance proficiency in PowerPoint.
- **Graphic Design:** I regularly use ADOBE Photoshop CC to create different visual elements for presentations.
- **Motion Graphics:** I can use Sony Vegas pro 9.0, Prezi, Windows Media Player or PowerPoint to create different video projects or presentations.
- **3D Modelling:** Enjoy using Sketch-Up or another Cad software to create different 3D projects or presentation materials.
- **Work Methodologies:** SCRUM, Waterfall

Languages:

- Romanian (native proficiency)
- English (bilingual proficiency)

Personal Projects and Additional Information

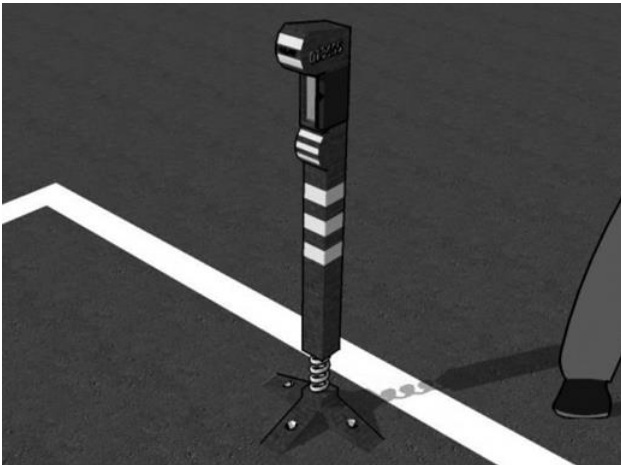

Personal project 5: Universal Smart Parking Solution V 1.0 - August 2017

Universal smart city parking solution designed to be scalable and decrease the price of parking while increasing revenue for shareholders.

Scope: Increase parking availability and decrease price of parking.

Created: 3D Design, Business Analysis Document, Wireframes

More details here: <https://goo.gl/HqScTG>

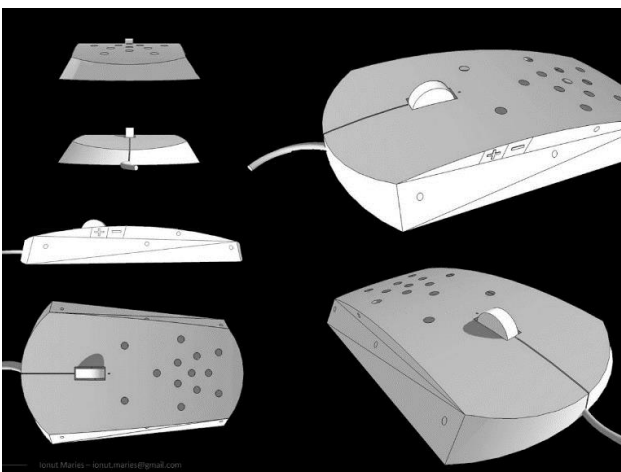

Personal Project 4: Sweat Free Mouse - July 2016

Sweat free mouse with internal vent and ceramic base for temperature control as well as antibacterial Snap-On cover for personal customization.

Scope: No more sweating when using a mouse.

Created: 3D Design, Fabrication Plan

More details here: <https://goo.gl/WES61R>

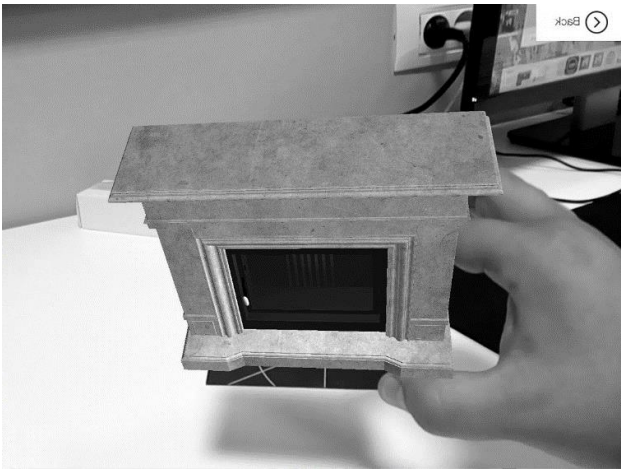

Personal Project 3: Augmented Reality Solution for Fireplace Presales – June 2016

AR solution that can be used by fireplace builders to show customers exactly how the fireplace they want to build will look like in their home before actually building it.

Scope: Better customer experience.

Created: Functional Software Prototype for Mobile Device

More details here: <https://goo.gl/t92UUh>

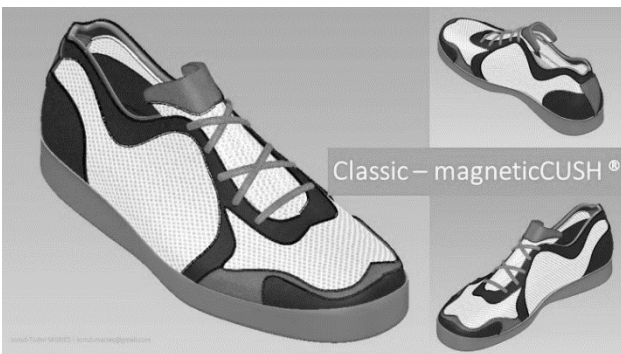

Personal Project 2: Failed Project – Magnetic sport shoes - January 2016

Sport shoes concept to use magnetic sole technology for better shock absorption as well as for better energy return.

Scope: Better shock absorption and energy return.

Created: 3D Design

More details here: <https://goo.gl/ooANzh>

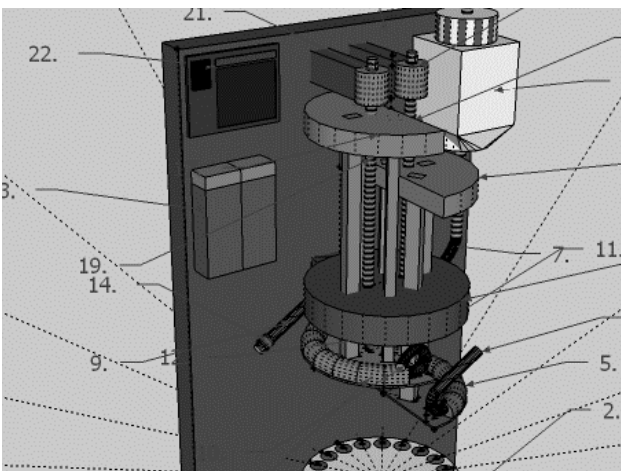

Personal Project 1: Romania A/00999 - December 2013

Low energy consumption water heating system using magnetic induction technology.

Scope: Using the same energy as a light bulb would use, the system should be able to heat a small 2 bed room apartment.

Created: 3D Design, Prototype, Patent Documentation

More details here: <https://goo.gl/2iuods>

Conferences and Fairs:

Technology

- **Delegate:** Mobile World Congress Barcelona (2014, 2015, 2016) and Apps World London (2014, 2016)
- Techsylvania 2014 and 2016, Innoteque 2016, Codecamp (2016, 2017, 2018)

Innovation

- econTEAM 2014 , LSRS and ONERA Innovation 2014, Cluj Innovation Days (2016, 2018)

Business

- ITB Berlin 2014
- Cluj Business Days 2014 and 2016
- Transylvanian Clusters International Conference

Professional Trainings:

- **Harvard Leadership and Communication Training – CAESAR Foundation** – participated in a one-week intensive leadership and communication training thought by Harvard Professor, Steve Jarding.
- **Sales Training Modul 1 - Accelera Consulting** – participated in a three-day intensive sales training from Accelera focused on the psychology of sales.

Competences:

- **Professional:** innovative, ambitious, dynamic, conscientious, competitive, diplomat.
- **Personal:** eager to learn and share knowledge, pleasant, cheerful, social and independent.
- **Driving license:** B Category.

Organizations and Networks:

- **MENSA Romania - Member** – member of the MENSA Romania organization.
- **League of Romanian Students Abroad (LSRS)** – alumnus and mentor for young students.

Passions:

- **Basketball:** I enjoy playing basketball whenever I have some free time.
- **Cooking:** I particularly enjoy cooking at home and experimenting with new recipes.
- **Learning:** I enjoy learning about new things and technologies and also thinking how they can be applied in other fields to solve problems.